

# Dähne Verlag

*Ich weiß.*

## Publishing house centralizes virtual storage environment with Open-E JovianDSS

Since 1970, Dähne Publishing is producing and distributing their DIY and pet publications. With about a dozen consumer publications and specialist journals, the publishing house offers an extensive portfolio for different interests, also via online portals, shopping guides and book publications.

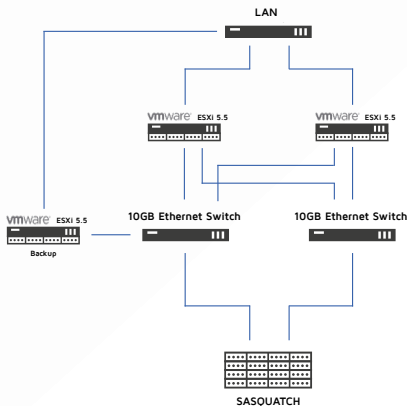

For its growing amount of data, Dähne publishing had been using an eight year old virtualized environment based on Open-E DSS V6. It was time to look for a new solution, preferably with the same or better performance and data throughput, as well as a similarly easy management. The service provider stayed the same, too: The project of developing a new storage concept was handed over to Open-E Platinum Partner and storage specialist Rausch Netzwerktechnik who Dähne Publishing had cooperated with for over 20 years already.

# Solution

Rausch Netzwerktechnik presented a new concept consisting of a centralized virtual environment with 10Gbit RJ45 – this time based on servers of their own brand Sasquatch with the ZFS-based storage software JovianDSS by Open-E.

## Benefits of the new solution:

- › Higher performance for a faster and more efficient management of all business-critical processes
- › Higher throughput, especially for data from the online portals
- › Easy management and maintenance with additional on-site support

With regards to hardware, 12 x 2TB mirrored HDDs were used. Additionally the setup contained a 4-Core CPU, 1 x 100GB Zil and 1 x 400GB L2ARC in the proven Sasquatch server. The complete system was installed and configured on-site by an engineer, to keep downtime to a minimum. The migration of the old data to the new system worked seamlessly as well.



# Hardware setup

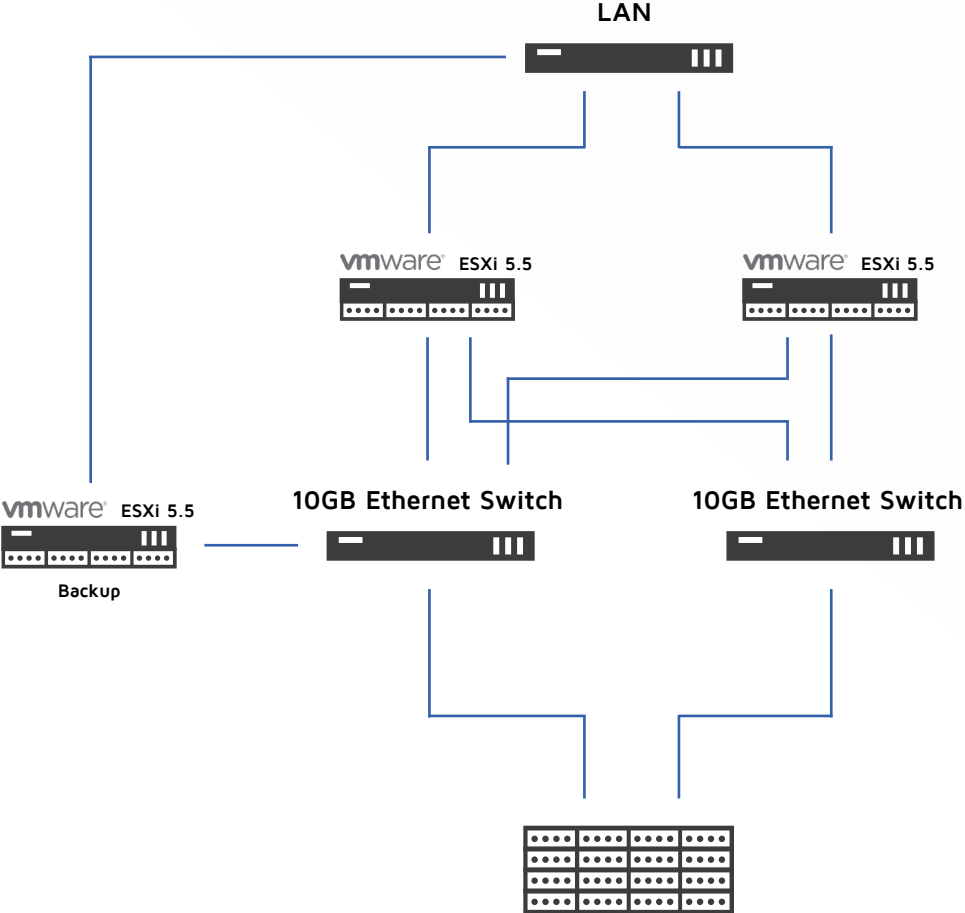

# About Dähne Publishing

Dähne Publishing was established in 1970 and is a successful family business, now in the second generation. Growing with a focus on do-it-yourself topics, the specialized publishing house extended the range of their publications to gardening, woodworks, pets, as well as fishkeeping, terrariums, dogs and garden ponds. The portfolio consists of about a dozen consumer publications and specialist journals, a variety of online portals and additional publications, including business and address directories, shopping guides and many books about fishkeeping, terrariums and garden ponds. More information on: [www.daehne.de](http://www.daehne.de)

# About Rausch Netzwerktechnik

Since 1998 we consider ourselves as your reliable partner, solution provider and developer, enabling technology innovations. Organizations as well as data centers around the globe trust in our standard and individual solutions to advance their business – we have already implemented more than 250,000 systems in a precisely fitting manner. And we even go a step further: Based on hardware of our own or of our long-time partners, we chose the right software for the operation of your server or storage cluster and build tailor-made solutions – delivery, launch and support are included as well! More on [www.rnt.de/en](http://www.rnt.de/en)

# About Open-E

Open-E, founded in 1998, is a well-established developer of IP-based storage management software. Its flagship product Open-E JovianDSS is a robust, award-winning storage application which offers excellent compatibility with industry standards, and is the easiest to use and manage. Additionally, it is of the most stable solutions on the market and undisputed price performance leader.

Thanks to its reputation, experience and business reliability, Open-E has become the technology partner of choice for industry-leading IT companies. Open-E accounts for over 30,000 installations world-wide and has received numerous industry awards and recognition, also with its product Open-E DSS V7.

For further information about Open-E, its products and partners, visit <http://www.open-e.com>

More information:

**Rausch Netzwerktechnik GmbH**

+49 (0)7243 59290 | [info@rnt.de](mailto:info@rnt.de)

**Open-E GmbH**

+49 (89) 800777 0 | [info@open-e.com](mailto:info@open-e.com)